

Do Not Take Measurements From The Drawing

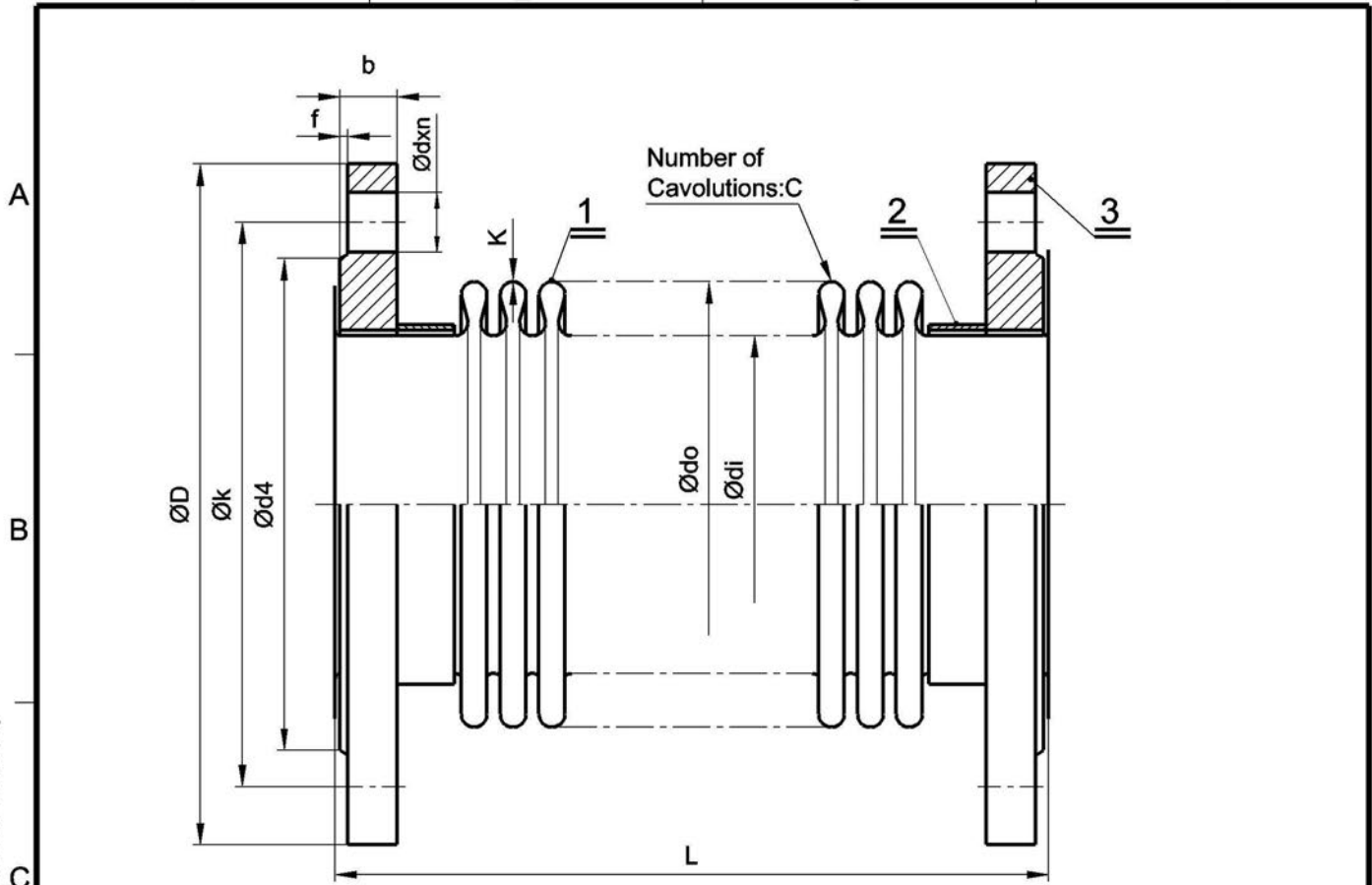

AXIAL: +20mm -40mm

SIZE	BELLOW				FLANGE						L	Axial Spring Rate at 21 °C in N/mm	Net Weights (kg)	Stock Code
	Ø di	Ø do	K	C	Ø D	Ø k	Ø d4	f	b	Ø dxn				
DN200	219,1	251,7	0,50mm	16	320	280	258	3	20	Ø18x8	295	93,5	13,33	HA200A010A37C
DN250	273	324,8	0,50mm	12	375	335	312	3	22	Ø18x12	285	41,2	18	HA200A010A38C
DN300	323,9	382	0,60mm	12	440	395	365	4	22	Ø23x12	300	58,3	24	HA200A010A39C

3	2	FLANGE	St 37.2	PN 6		
2	2	BAND	AISI 321			
1	1	BELLOW	AISI 321	PN 2,5		

ITEM	QTY	PART NAME	MATERIAL	SIZE	DRAWING NO	EXPLANATION
------	-----	-----------	----------	------	------------	-------------

	NAME	DATE	SIGNATURE
DRAWER		24.12.2008	
CONTROL			
APPROVAL			

Wellflex GmbH
 Erasmusstr. 3 • D-28217 Bremen / Germany
 Tel.: +49 (0)421 439315
 Fax: +49 (0)421 441123
 Mail: info@Wellflex.de
 Web: www.Wellflex.de

SCALE	EXPANSION JOINT WITH FLOATING FLANGES Typ: HAF - PN 2,5 - L60							
	>0.5	>3	>6	>30	>120	>400	>1000	>2000
	<3	<6	<30	<120	<400	<1000	<2000	<4000
	± 0.1	± 0.1	± 0.2	± 0.3	± 0.5	± 0.8	± 1.2	± 2
	GENERAL MEASURE TOL.DIN7168 MID.							

	MATERIAL	QTY	DRAWING NUMBER :
			EDITION NUMBER: 1

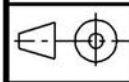

FIRM DRAWING NUMBER :

WEIGHT :